

Bourdon tube pressure gauge, stainless steel

For the process industry, panel mounting

Model PG23CP, NS 63 [2 1/2"] and 100 [4"]

WIKA data sheet PM 02.24



For further approvals,
see page 6

Applications

- For gaseous and liquid aggressive media that are not highly viscous or crystallising, also in aggressive environments
- Chemical and petrochemical industries, oil and gas industry, power engineering and also water and wastewater technology
- Particularly suitable for use in wellhead control panels (WHCPs) and hydraulic power units (HPUs)

Special features

- Fully welded mounting ring to avoid the ingress of water into the control panel (ingress protection IP66)
- Completely from stainless steel
- Safety level "S1" or "S3" per EN 837-1 or per ASME B40.100
- Scale ranges from 0 ... 0.6 to 0 ... 1,600 bar or 0 ... 10 to 0 ... 20,000 psi
- QR code on dial links to instrument-specific information

Description

This high-quality Bourdon tube pressure gauge has been designed especially for the process industry.

Typical measuring points are located at operating units and operator panels, e.g. hydraulic power units (HPUs). A high-quality front bezel is used for secure mounting of the instrument. In most cases, the mounting situations require ingress protection IP66. For this reason, the sealing of the model PG23CP to the control panel is made using a fully welded mounting ring and a matched flat gasket.

The use of high-quality stainless steel materials and the robust design are geared to applications in the chemical and process engineering industries. Thus the instrument is suitable for liquid and gaseous media, also in aggressive environments.



Bourdon tube pressure gauge, model PG23CP, NS 100 [4"]

WIKA produces and qualifies the pressure gauge in accordance with the standards EN 837-1 and ASME B40.100.

Model PG23CP complies with at least safety level "S1", with blow-out device at the rear of the instrument. The safety level "S3" version is made up of a non-splintering window, a solid baffle wall between measuring system and dial and a blow-out back. In the event of a failure, the user is protected at the front side, as media or components can only be ejected via the rear of the case.

The QR code on the dial allows instrument-specific information such as the serial number, the order number, certificates and other product data to be retrieved from the internet easily and in the long term.

Specifications

Basic information	
Standard	<ul style="list-style-type: none"> ■ EN 837-1 ■ ASME B40.100 <p>For information on the "Selection, installation, handling and operation of pressure gauges", see technical information IN 00.05.</p>
Further version	<ul style="list-style-type: none"> ■ Oil- and grease-free for oxygen ■ Per NACE ¹⁾ MR0175 / ISO 15156, use in H₂S-containing environments in oil and gas production ■ With pre-volume deflagration flame arrester ²⁾ for mounting to zone 0 (EPL Ga); model 910.21; see data sheet AC 91.02
Nominal size (NS)	<ul style="list-style-type: none"> ■ Ø 63 mm [2 ½"] ■ Ø 100 mm [4"]
Connection location	<ul style="list-style-type: none"> ■ Lower back mount ■ Centre back mount
Window	<ul style="list-style-type: none"> ■ Laminated safety glass ■ Polycarbonate
Case	
Design	<ul style="list-style-type: none"> ■ Safety level "S1" per EN 837-1: with blow-out device ■ Safety level "S3" per EN 837-1: with solid baffle wall (Solidfront) and blow-out back <p>Scale ranges ≤ 0 ... 16 bar [≤ 0 ... 300 psi] with equalising valve to vent and reseal case</p>
Material	<ul style="list-style-type: none"> ■ Stainless steel 1.4301 (304) ■ Stainless steel 1.4571 (316Ti) ■ Stainless steel 1.4404 (316L)
Ring	Bayonet bezel, stainless steel
Mounting	Control panel version with seal
Case filling	<ul style="list-style-type: none"> ■ Without ■ Glycerine ■ Glycerine-water mixture for NS 100 [4"] with scale range ≤ 0 ... 2.5 bar [≤ 0 ... 40 psi] or for NS 63 [2 ½"] with scale range ≤ 0 ... 4 bar [≤ 0 ... 60 psi] ■ Silicone oil
Movement	<ul style="list-style-type: none"> ■ Stainless steel ■ Stainless steel 1.4404 (316L) ■ everlast® version

1) General information about NACE standards; see data sheet IN 00.21

2) Only for instruments with Ex approval

Measuring element	
Type of measuring element	Bourdon tube, C-type or helical type
Material	Stainless steel 1.4404 (316L)
Leak tightness	<ul style="list-style-type: none"> ■ Helium tested, leakage rate: < 5 · 10⁻³ mbar l/s ■ Helium tested, leakage rate: < 1 · 10⁻⁶ mbar l/s

Accuracy specifications		
Accuracy class		
NS 63 [2 ½"]	■ EN 837-1	Class 1.6
	■ ASME B40.100	±2 % ±1 % ±2 % of measuring span (grade A)
NS 100 [4"]	■ EN 837-1	Class 1.0
	■ ASME B40.100	±1 % of measuring span (grade 1A)

Accuracy specifications	
Temperature error	On deviation from the reference conditions at the measuring system: $\leq \pm 0.4\%$ per 10 °C [$\leq \pm 0.4\%$ per 18 °F] of full scale value
Reference conditions	
Ambient temperature	+20 °C [+68 °F]

Scale ranges

bar	
0 ... 0.6 ¹⁾	0 ... 40
0 ... 1	0 ... 60
0 ... 1.6	0 ... 100
0 ... 2.5	0 ... 160
0 ... 4	0 ... 250
0 ... 6	0 ... 400
0 ... 10	0 ... 600
0 ... 16	0 ... 1,000
0 ... 25	0 ... 1,600

kg/cm ²	
0 ... 0.6 ¹⁾	0 ... 40
0 ... 1	0 ... 60
0 ... 1.6	0 ... 100
0 ... 2.5	0 ... 160
0 ... 4	0 ... 250
0 ... 6	0 ... 400
0 ... 10	0 ... 600
0 ... 16	0 ... 1,000
0 ... 25	0 ... 1,600

kPa	
0 ... 60 ¹⁾	0 ... 4,000
0 ... 100	0 ... 6,000
0 ... 160	0 ... 10,000
0 ... 250	0 ... 16,000
0 ... 400	0 ... 25,000
0 ... 600	0 ... 40,000
0 ... 1,000	0 ... 60,000
0 ... 1,600	0 ... 100,000
0 ... 2,500	0 ... 160,000

MPa	
0 ... 0.06 ¹⁾	0 ... 4
0 ... 0.1	0 ... 6
0 ... 0.16	0 ... 10
0 ... 0.25	0 ... 16
0 ... 0.4	0 ... 25
0 ... 0.6	0 ... 40
0 ... 1	0 ... 60
0 ... 1.6	0 ... 100
0 ... 2.5	0 ... 160

psi	
0 ... 10 ¹⁾	0 ... 1,000
0 ... 15	0 ... 1,500
0 ... 30	0 ... 2,000
0 ... 60	0 ... 3,000
0 ... 100	0 ... 4,000
0 ... 160	0 ... 5,000
0 ... 200	0 ... 6,000
0 ... 300	0 ... 7,500
0 ... 400	0 ... 10,000
0 ... 600	0 ... 15,000
0 ... 800	0 ... 20,000

1) Not available for NS 63 [2 ½"]

Vacuum and compound scale ranges

bar	
-0.6 ... 0 ¹⁾	-1 ... +5
-1 ... 0	-1 ... +9
-1 ... +0.6	-1 ... +15
-1 ... +1.5	-1 ... +24
-1 ... +3	-

MPa	
-0.06 ... 0 ¹⁾	-0.1 ... +0.5
-0.1 ... 0	-0.1 ... +0.9
-0.1 ... +0.06	-0.1 ... +1.5
-0.1 ... +0.15	-0.1 ... +2.4
-0.1 ... +0.3	-

kPa	
-60 ... 0 ¹⁾	-100 ... +500
-100 ... 0	-100 ... +900
-100 ... +60	-100 ... +1,500
-100 ... +150	-100 ... +2,400
-100 ... +300	-

psi	
-30 inHg ... 0	-30 inHg ... +100
-30 inHg ... +15	-30 inHg ... +160
-30 inHg ... +30	-30 inHg ... +200
-30 inHg ... +60	-30 inHg ... +300

1) Not available for NS 63 [2 ½"]

Further details on: scale ranges	
Special scale ranges	Other scale ranges on request
Unit	<ul style="list-style-type: none"> ■ bar ■ psi ■ kg/cm² ■ kPa ■ MPa
Increased overload safety	<ul style="list-style-type: none"> ■ Without ■ 2 times ■ 3 times ■ 4 times ■ 5 times <p>The possibility of selection depends on scale range and nominal size</p>
Vacuum resistance	<ul style="list-style-type: none"> ■ Without ■ Vacuum-resistant to -1 bar
Dial	
Scale colour	Black
Material	Aluminium
Special scale	<ul style="list-style-type: none"> ■ Without ■ With temperature scale for refrigerant, e.g. for NH₃: R 717 <p>Other scales or customised dials, e.g. with red mark, circular arcs or circular sectors, on request</p>
Pointer	
Instrument pointer	<ul style="list-style-type: none"> ■ Standard pointer, aluminium, black ■ Adjustable pointer, aluminium, black
Mark pointer / Drag pointer	<ul style="list-style-type: none"> ■ Without ■ Red mark pointer on dial, fixed ■ Red mark pointer on window, adjustable ■ Mark pointer on bayonet bezel, adjustable ■ Red drag pointer on window, adjustable
Pointer stop pin	<ul style="list-style-type: none"> ■ Without ■ At zero point (only for NS 63 [2 ½"]) ■ At 6 o'clock (only for NS 100 [4"])



Process connection	
Standard	<ul style="list-style-type: none"> ■ EN 837-1 ■ ISO 7 ■ ANSI/B1.20.1
Size	
EN 837-1	<ul style="list-style-type: none"> ■ G 1/8 B, male thread ■ G 1/4 B, male thread ■ G 1/2 B, male thread ■ M12 x 1.5, male thread ■ M20 x 1.5, male thread
ISO 7	<ul style="list-style-type: none"> ■ R 1/4, male thread ■ R 1/2, male thread
ANSI/B1.20.1	<ul style="list-style-type: none"> ■ 1/4 NPT, male thread ■ 1/2 NPT, male thread
Restrictor	<ul style="list-style-type: none"> ■ Without ■ Ø 0.6 mm [0.024"], stainless steel ■ Ø 0.3 mm [0.012"], stainless steel
Material (wetted)	
Process connection	Stainless steel 1.4404 (316L)
Bourdon tube	Stainless steel 1.4404 (316L)

Other process connections on request









Operating conditions		
Medium temperature		
Instruments without filling	-40 ... +200 °C [-40 ... +392 °F]	
Instruments with glycerine filling	-20 ... +100 °C [-4 ... +212 °F]	
Instruments with silicone oil filling	-40 ... +100 °C [-40 ... +212 °F]	
Ambient temperature		
Instruments without filling or with silicone oil filling	-40 ... +60 °C [-40 ... +140 °F]	
Instruments with glycerine filling	-20 ... +60 °C [-4 ... +140 °F]	
Pressure limitation		
NS 63 [2 1/2"]	Steady	3/4 x full scale value
	Fluctuating	2/3 x full scale value
	Short time	Full scale value
NS 100 [4"]	Steady	Full scale value
	Fluctuating	0.9 x full scale value
	Short time	1.3 x full scale value
Ingress protection per IEC/EN 60529	<ul style="list-style-type: none"> ■ IP65 ■ IP66 ¹⁾ 	

1) Not available for case designs with safety level "S1" and scale ranges < 0 ... 20 bar [0 ... 400 psi]

Approvals

Logo	Description	Region
	EU declaration of conformity Pressure Equipment Directive PS > 200 bar, module A, pressure accessory	European Union
	UKCA Pressure equipment (safety) regulations	United Kingdom
-	CRN Safety (e.g. electr. safety, overpressure, ...) For full scale value $\leq 1,000$ bar	Canada

Optional approvals

Logo	Description	Region
 	EU declaration of conformity ATEX directive Hazardous areas - Ex h Gas II 2G Ex h IIC T6 ... T1 Gb X Dust II 2D Ex h IIIC T85°C ... T450°C Db X	European Union
	UKCA Equipment and protective systems intended for use in potentially explosive atmospheres regulations	United Kingdom
	EAC Hazardous areas	Eurasian Economic Community
	Ex Ukraine Hazardous areas	Ukraine
	PAC Kazakhstan Metrology, measurement technology	Kazakhstan
-	MChS Permission for commissioning	Kazakhstan
-	PAC Ukraine Metrology, measurement technology	Ukraine
	PAC Uzbekistan Metrology, measurement technology	Uzbekistan
-	PAC China Metrology, measurement technology	China
	DNV Ships, shipbuilding (e.g. offshore)	International

Manufacturer's declaration

Logo	Description
-	Pressure Equipment Directive (PED) for maximum allowable pressure $PS \leq 200$ bar
-	Suitability of wetted materials for drinking water per European 4MS initiative

Certificates

Certificates	
Certificates	<ul style="list-style-type: none"> ■ 2.2 test report per EN 10204 (e.g. state-of-the-art manufacturing, indication accuracy) ■ 3.1 inspection certificate per EN 10204 (e.g. material proof for wetted metal parts, indication accuracy) ■ PCA calibration certificate, traceable and accredited in accordance with ISO/IEC 17025 ■ Calibration certificate by a national accreditation body, traceable and accredited in accordance with ISO/IEC 17025 on request
Recommended calibration interval	1 year (dependent on conditions of use)

→ For approvals and certificates, see website

Patents, property rights

Patent number	Description
US Design D1051747S, CPC CN 01677074, DE Design 402022100171, EU Design 402022100171, IR Design DM/222416, EU 3D trademark 018659564	Design patent WIKA blue identity

The WIKA blue identity design is protected in various countries under various rights.

Model PG23CP, safety level "S1"

NS 63 [2 1/2"], centre back mount

≤ 16 bar [≤ 300 psi] with vent valve
 > 16 bar [> 300 psi] without vent valve

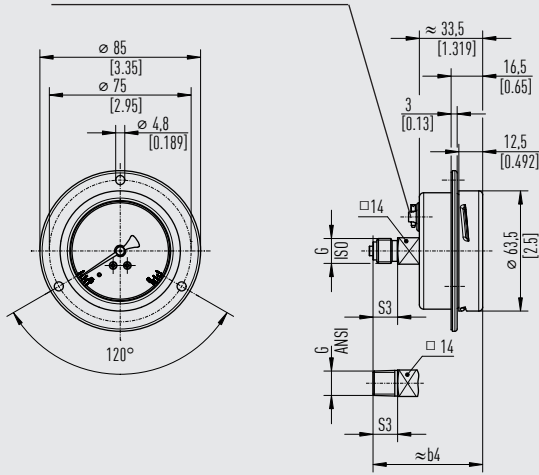

14123681.02

NS	Weight	
	Without filling	With filling
63 [2 1/2"]	Approx. 0.25 kg [0.55 lb]	Approx. 0.27 kg [0.60 lb]

Process connection with thread per EN 837-1

NS	G	Dimensions in mm [in]	
		b4	S3
63 [2 1/2"]	G 1/8 B	55 [2.17]	10 [0.39]
	G 1/4 B	58 [2.28]	13 [0.51]

Process connection with thread per ANSI/B1.20.1

NS	G	Dimensions in mm [in]	
		b4	S3
63 [2 1/2"]	1/8 NPT	55 [2.17]	10 [0.39]
	1/4 NPT	58 [2.28]	13 [0.51]

Model PG23CP, safety level "S1"

NS 100 [4"], lower back mount

≤ 16 bar [≤ 300 psi] with vent valve
 > 16 bar [> 300 psi] without vent valve

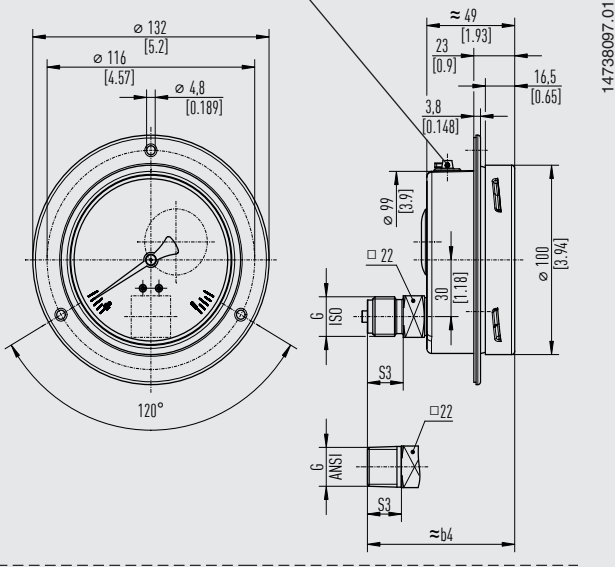

NS	Weight	
	Without filling	With filling
NS 100 [4"]	Approx. 0.73 kg [1.61 lb]	Approx. 0.93 kg [2.05 lb]









Process connection with thread per EN 837-1

NS	G	Dimensions in mm [in]	
		b4	S3
NS 100 [4"]	G 1/8 B	72.5 [2.85]	10 [0.39]
	G 1/4 B	75.5 [2.97]	13 [0.51]
	G 3/8 B	78.5 [3.09]	16 [0.63]
	G 1/2 B	82.5 [3.25]	20 [0.79]

Process connection with thread per ANSI/B1.20.1

NS	G	Dimensions in mm [in]	
		b4	S3
NS 100 [4"]	1/8 NPT	72.5 [2.85]	10 [0.39]
	1/4 NPT	75.5 [2.97]	13 [0.51]
	3/8 NPT	77.5 [3.05]	15 [0.59]
	1/2 NPT	81.5 [3.21]	19 [0.75]

Accessories and spare parts

Model	Description
	910.17 Seals → See data sheet AC 09.08
	910.15 Syphons → See data sheet AC 09.06
	910.13 Overpressure protector → See data sheet AC 09.04
	IV1 Needle valve and multiport needle valve → See data sheet AC 09.22
	IV2 Block-and-bleed valve → See data sheet AC 09.19
	IVM Monoflange, process and instrument version → See data sheet AC 09.17
	BV Ball valve, process and instrument version → See data sheet AC 09.28
	IBF2, IBF3 Monoblock with flange connection → See data sheet AC 09.25

Ordering information

Model / Nominal size / Scale range / Process connection / Connection location / Options

© 06/2015 WIKA Alexander Wiegand SE & Co. KG, all rights reserved.

The specifications given in this document represent the state of engineering at the time of publishing.

We reserve the right to make modifications to the specifications and materials.

In case of a different interpretation of the translated and the English data sheet, the English wording shall prevail.

